

CONFIDENTIAL

| | REVISION DESCRIPTION | APP. | DRW. | DATE | CHANGE No. |
|--------|----------------------|-------|-------|----------|------------|
| △B x 3 | Add mid-plate | T. N. | K. K. | '23/10/4 | DC23-0026 |
| △C x | | | | | |
| △D x | | | | | |

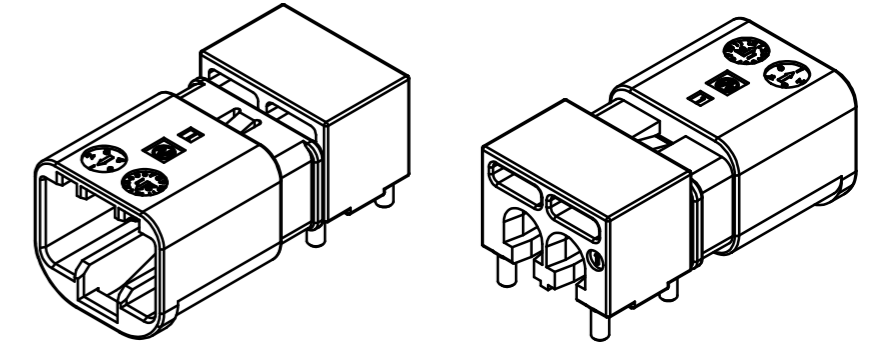
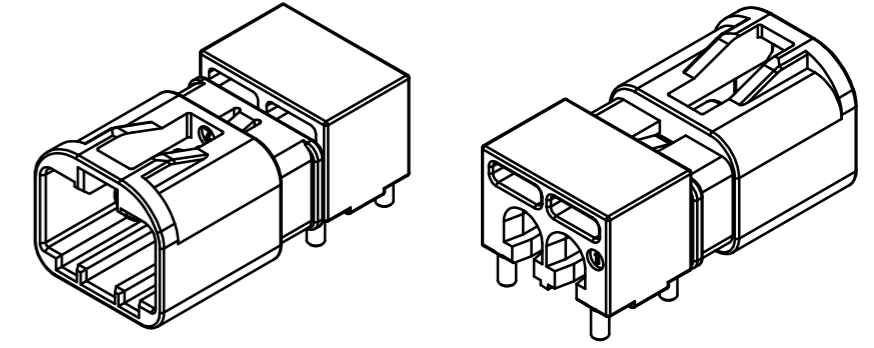
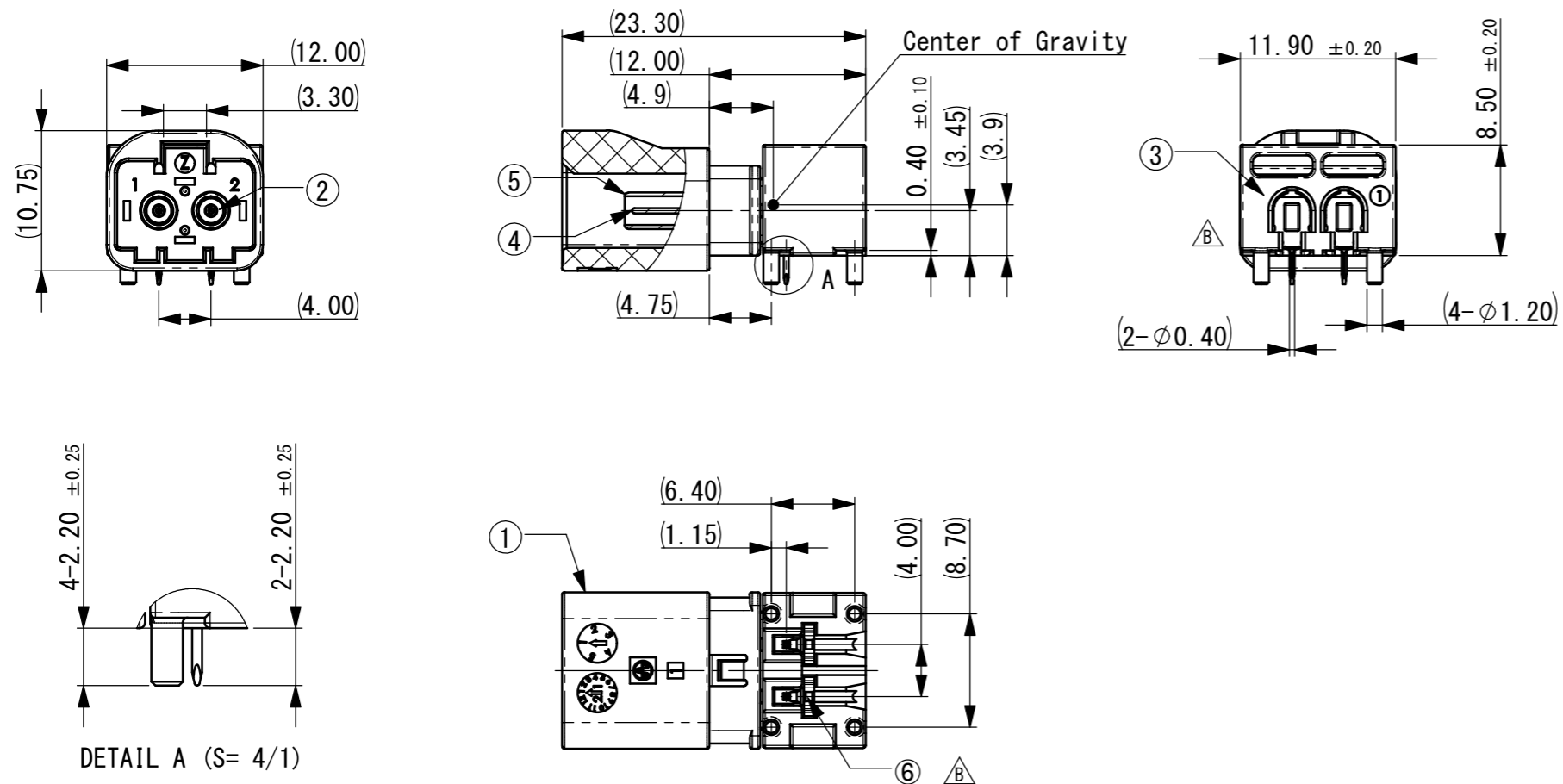

Notes.

1. Connector Part Number:

HFU106P-912x-0x-VE

x: Key Code

0: Standard Plug Orientation
1: 180° Plug Orientation

2. RoHS compliant

3. All contact dimensions referenced are post plated.

| Component Table | | | | |
|-----------------|-------------|------|-----------------|--------------------------------------|
| ITEM | DESCRIPTION | QTY. | MATERIAL | CONTENT |
| △B 6 | Mid-plate | 2 | Stainless Steel | - |
| 5 | Cylinder | 2 | Stainless Steel | Ni-Sn |
| 4 | Contact | 2 | Brass | Contact: Ni-Ag Solder Tail: Ni-Sn |
| 3 | Die-Cast | 1 | Zinc Alloy | Cu-Ni-Sn |
| 2 | Insulator | 2 | LCP | UL94V-0; Black |
| 1 | Housing | 1 | PA | UL94V-0 |

| Key Code | | A | B | C | D | Z |
|---------------------------|--|-----------|-----------|-----------|---------------|------------|
| Standard Plug Orientation | | | | | | |
| | | | | | | |
| 180° Plug Orientation | | | | | | |
| | | | | | | |
| Color | | Black | White | Blue | Claret Violet | Water Blue |
| RAL | | sim. 9005 | sim. 9010 | sim. 5012 | sim. 4004 | sim. 5021 |

Key Code Details

Tolerances ±0.30 unless otherwise specified.
() Reference value

| | | | | | | | |
|------------|-----|------|--------------|------------|-----------|-----------|--|
| SCALE | 2:1 | APP. | APP. | CHK. | DRW. | DSGN. | |
| DIMENSION | mm | | '22/02/10 | '22/02/10 | '21/07/21 | '21/07/21 | |
| ANGLE PROJ | 3rd | | T. Nishimura | K. Kikuchi | S. Isaza | S. Isaza | |

CLASS MiniFAKRA 1x2
Part No. HFU106P-912x-0x-VE
DRW No. YEU-A4379 Sheet No. 1 / 2 REV. B

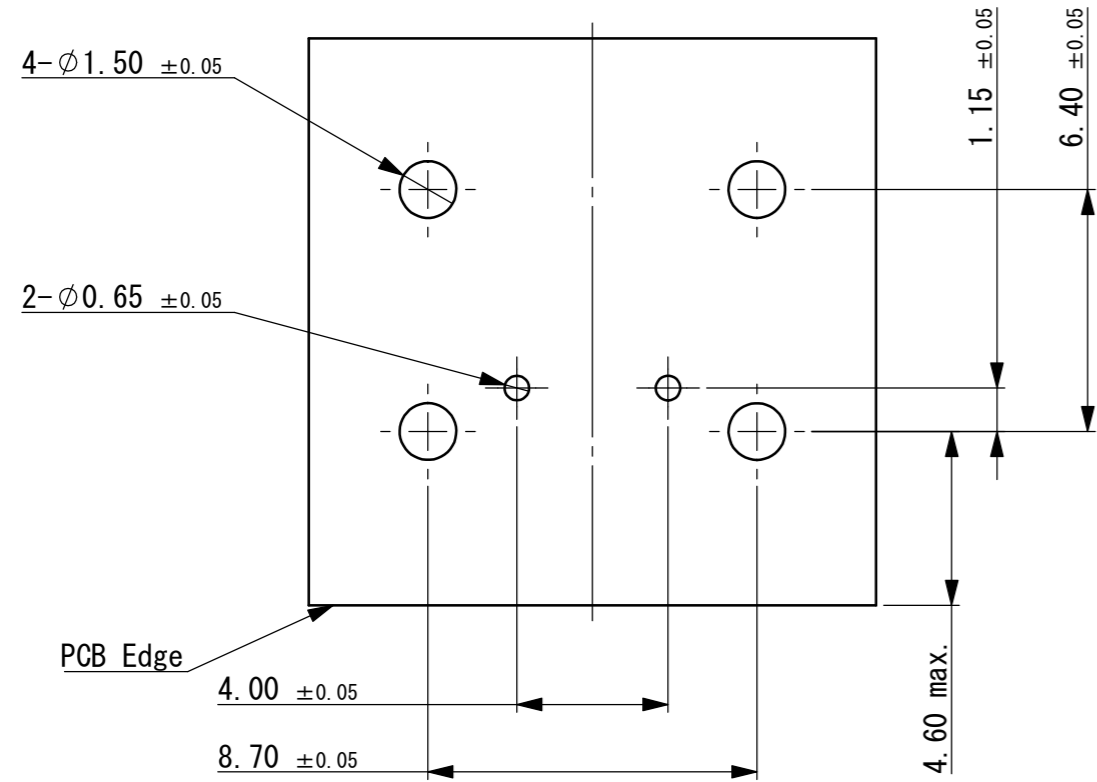

**PCB Hole Pattern
(FOR REFERENCE ONLY)**

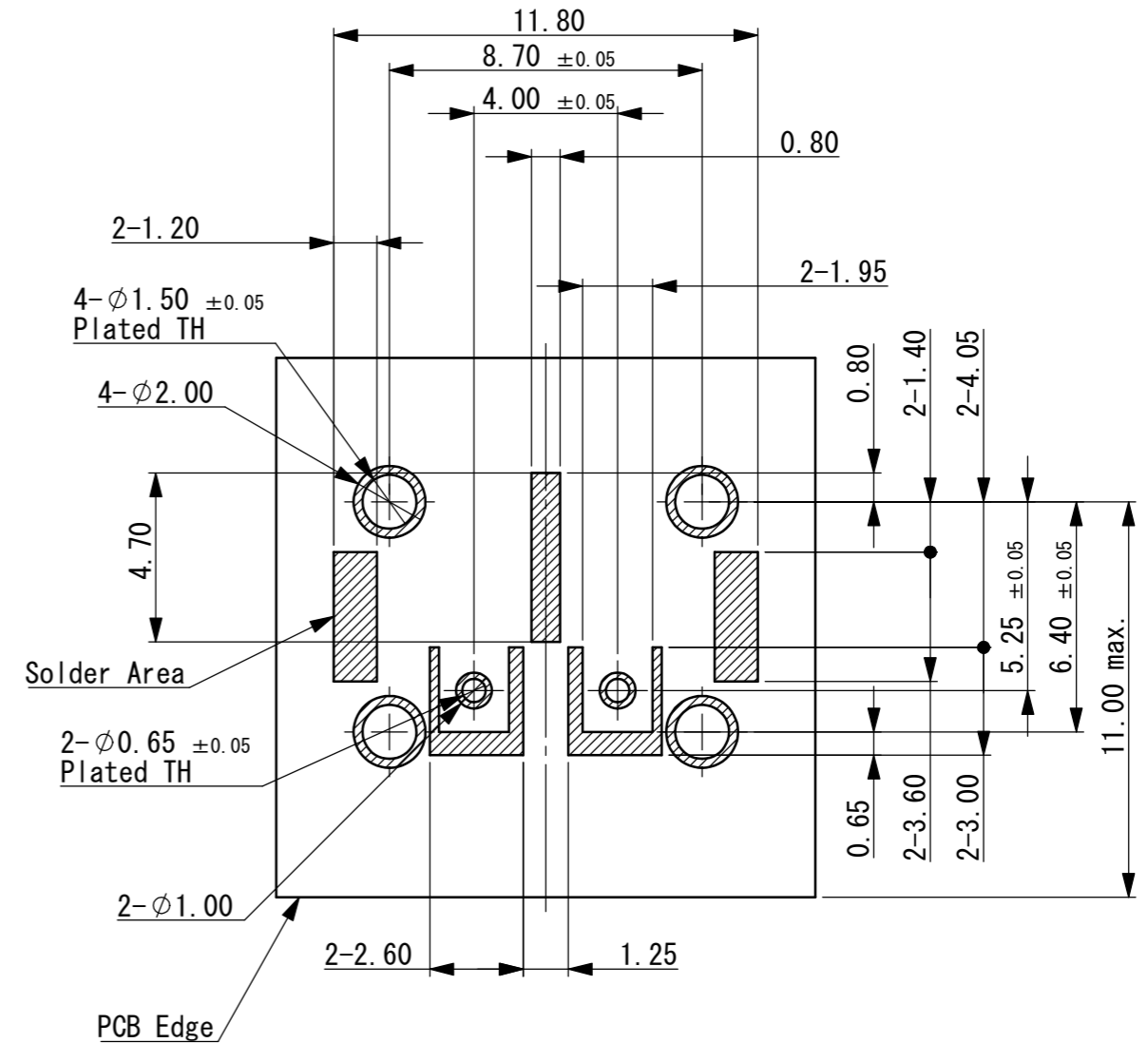

**PCB Layout for Reflow Solder
(FOR REFERENCE ONLY)**

**Recommended PCB Footprint
(FOR REFERENCE ONLY)**

| | | | | | | | |
|--|-----|------|--------------|------------|-----------|---------------------|---------------------------|
| | | | | | | | |
| Tolerances \pm 0.30 unless otherwise specified. () Reference value | | | | | | CLASS MiniFAKRA 1x2 | |
| SCALE | 5:1 | APP. | APP. | CHK. | DRW. | DSGN. | Part # HFU106P-912x-0x-VE |
| DIMENTION | mm | | '22/02/10 | '22/02/10 | '21/07/21 | '21/07/21 | DRW No. YEU-A4379 |
| ANGLE PROJ | 3rd | | T. Nishimura | K. Kikuchi | S. Isaza | S. Isaza | Sheet No. 2 / 2 |
| | | | | | | | REV. B |